

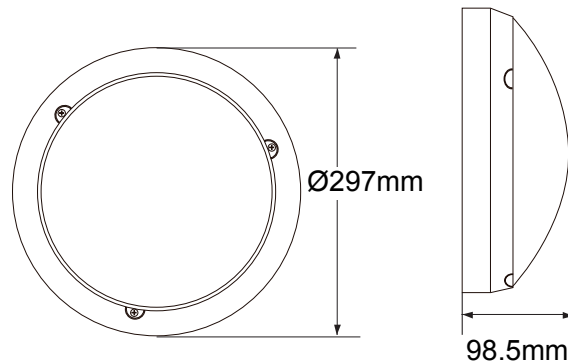



# LX-LD-106P Microwave Sensor Lamp Instruction



## Summary

Packing list in	Quantity
Microwave Sensor Lamp LEDS 96PCS	1X
 Φ6 Plastic expansion	4X
 3x30 Screw	4X
 Φ3 Sealing ring	3X
 4x12 Y type Stainless Screw	3X

**IP 44**

This is a microwave sensor switches controlled LED lights.,the microwave sensor was built into the lamp ,it has 96pcs high brightness LEDs inside ,with total power of 15 watts.which can generate almost the same brightness when compared to 150 watt incandescent lamp,the microwave sensor switch is a new type automatic switch that comes after voice switch ,and infrared sensor switch .The detection way has the below advantages compared with other as follows: 1. Non-contact detection, 2. Suitable for bad environment, immune to temperature, humidity, noise, air, dust, light...3.RF interference ability, 4. Transmission power only 0.2 mW, It will not harm the human body. Simple installation+ easy wiring.

We adopt this sensitive advanced sensor switche in lighting control, enabling the light to turn on automatically when one comes , automatically turn off when one goes out In addition to the widely usage in the aisle stairs,living room and bedrooms , it also can be installed in the bathroom.

The built-in microwave sensor switch can penetrate plastic, glass, wood . So it can be installed in glass or plastic shell lamp This allows the application of microwave sensor switch in different styles of lights for energy control. Now, we can provide a variety of microwave sensor LED lamps to meet the needs of different people with different preferences.



Use high quality PC lampshade.Strengthen the flexible refraction of light.And its function of anti-ultraviolet makes the shade not easy to turn yellow and be broken.



LED lamps than incandescent bulbs province electricity 80%;fluorescent lamps province electricity than 50%

## Name of each part

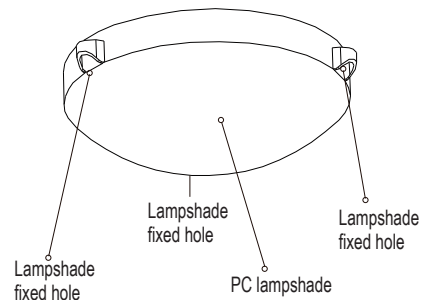
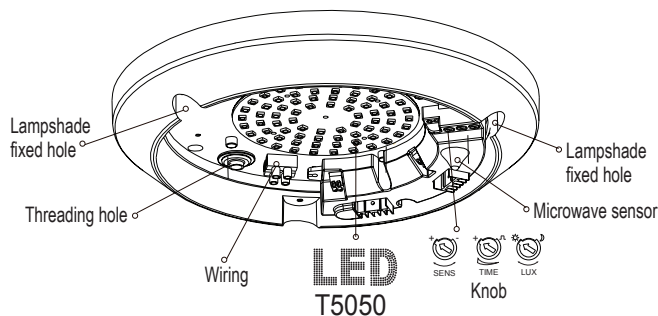

## Specifications

Power source: 220-240V/AC  
 Power frequency: 50Hz  
 HF system: 5.8GHz CW electric wave, ISM wave band  
 Rated load: 15W Max.  
 Transmission power: <0.2mW  
 Luminous flux: 848lm  
 Color temperature: 3400K-3700K  
 Time setting: 6sec to 12min(adjustable)  
 Detection angle: 360°

Detection range: 1-10m (radii.)(adjustable)  
 Light-control: 10-2000LUX(adjustable)  
 Standby power: <0.9W  
 Installation: ceiling mount  
 Weight: about 1.03 kg  
 Lamp part  
 LED quantity: 96PCS  
 LED specifications: T5050

## Sensor information

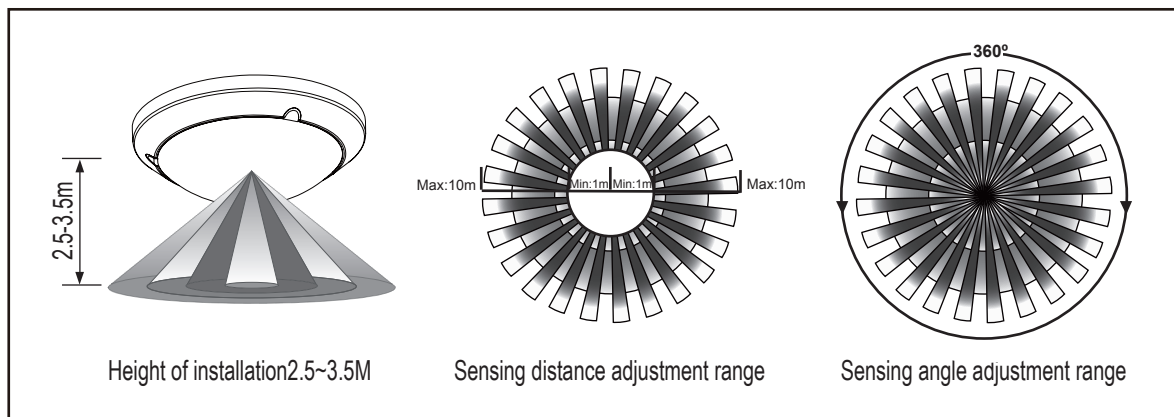

## Spectrogram

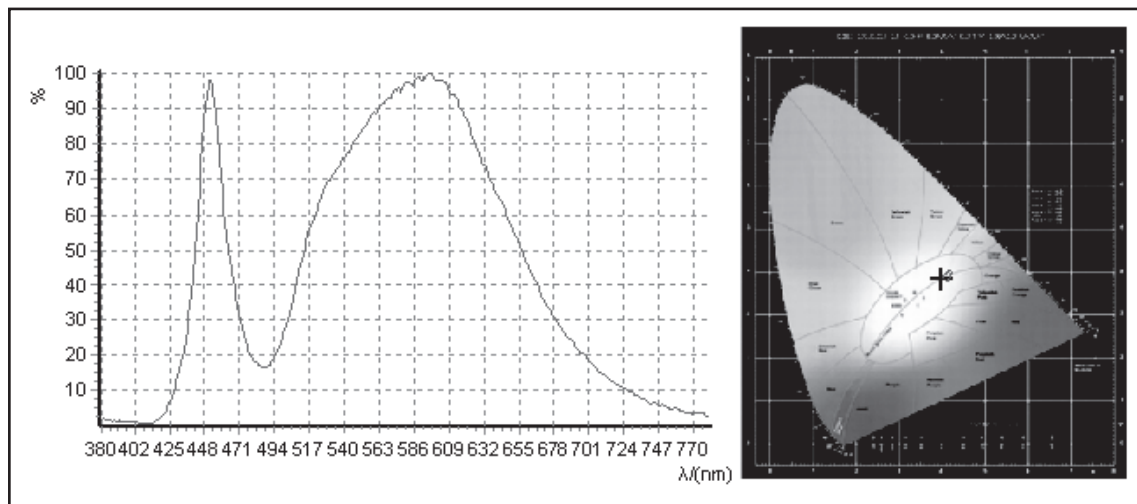

## Procedure of installation



### Warning!

1. Please keep it away from the children.
2. Please avoid fire/high temperature/damp places for installation.
3. Please confirm when shut off the power cord access.

### Note: Please bring the following tools



Pencil

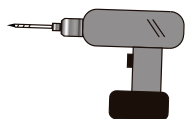

Electric drill

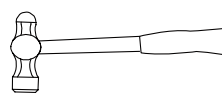

Hammer

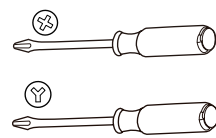

Screwdriver

- Step1 Turn off the screw to take down the lampshade (as follow: the product should be separated into two parts as A and B)

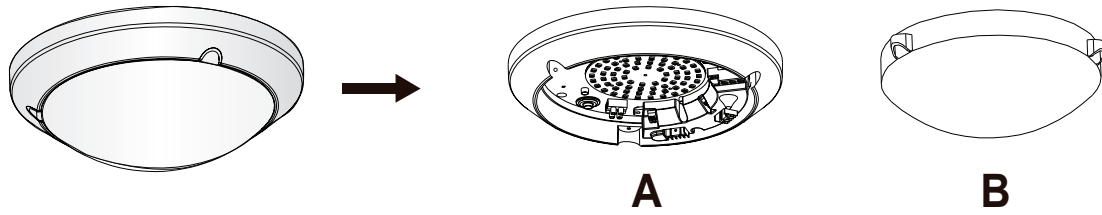

Fig.1

- Step2 Turn the knobs to the ideal conditions (as Fig.2)

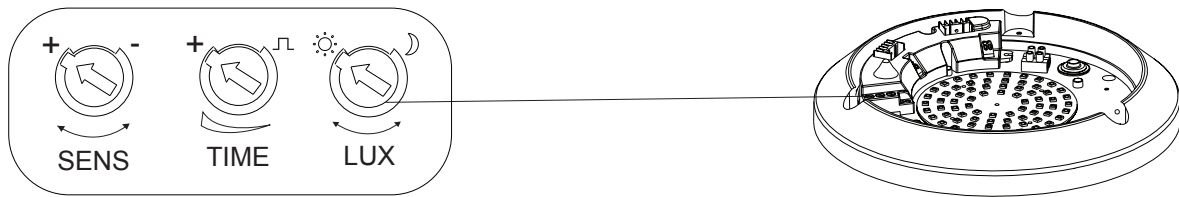

Fig.2

## Detection range setting (sensitivity)



Detection range is the term used to describe the radii of the more or less circular detection zone produced on the ground after mounting the sensor light at a height of 2.5m, turn the detection range control fully anti-clockwise to select minimum detection range (approx.1m radii), and fully clockwise to select maximum detection range (approx.10m radii).

**NOTE:** the above detection range is gained in the case of a person who is between 1.6m~1.7m tall with middle figure and moves at a speed of 1.0~1.5m/sec. if person's stature, figure and moving speed change, the detection range will also change.

In different cases, the sensitivity of the lights has certain deviation.

**ATTENTION:**When use this product, please adjust the sensitivity to an appropriate position you need, please do not adjust the sensitivity to maximum, to avoid the product does not work normally caused by wrong motion. Because the sensitivity is too high easily detect the wrong motion by wind blowing leaves & curtains, small animals, and the wrong motion by interference of power grid & electrical equipment. All those lead the product does not work normally !

When the product does not work normally, please try to lower the sensitivity appropriately, and then test it.

## Time setting



The light can be set to stay ON for any period of time between approx. 6sec(turn fully anti-clockwise) and a maximum of 12min(turn fully clockwise). Any movement detected before this time elapse will re-start the timer. It is recommended to select the shortest time for adjusting the detection zone and for performing the walk test.

**NOTE:** After the light switches OFF, it takes approx. 1sec before it is able to start detecting movement again. The light will only switch on in response to movement once this period has elapsed.

## Light-control setting



The chosen light response threshold can be infinitely from approx. 10-2000lux. Turn it fully anti-clockwise to select dusk- to-dawn operation at about 10 lux. Turn it fully clockwise to select daylight operation at about 2000lux. The knob must be turned fully clockwise when adjusting the detection zone and performing the walk test in daylight.

**Note: Please don't adjust the three functional buttons to excess. That is because the three functional buttons were connected to the components directly, there is a small stopper in each of the three components, when you adjust the buttons from start to end, the excessive turn will damage the stopper, and lead to the 360° non-stop turn around. The adjust range limit is 270°, please do pay attention to this.**

- Step3 Put the base of the product on the ceiling to make the drilling mark (as Fig.3)
- Step4 Install the product on the place where you marked (as Fig.4)

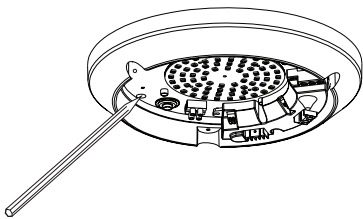

Fig.3

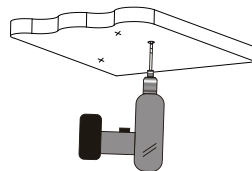

Fig.4



### Warning!

When you are drilling ,please make sure you wear glasses and dust masks to prevent the dust fly into the nose and throat causing unnecessary trouble

- Step5 Knock the plastic expansion screw into the hole which you drill (as Fig.5)
- Step6 Put the power line through the line hole to connect on the wiring (as Fig.6)

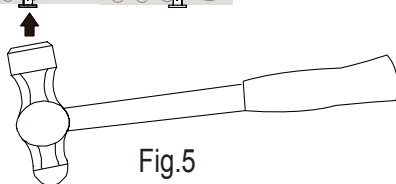
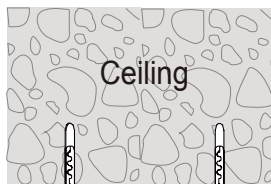

Fig.5

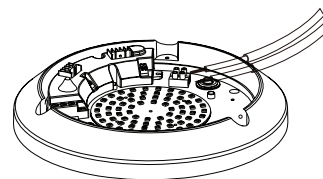
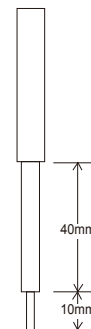

Fig.6



- Step7 Fix the base of the product on the selected place with the screws (as Fig.7)

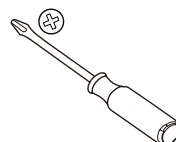
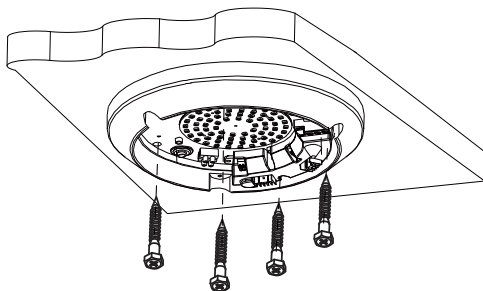
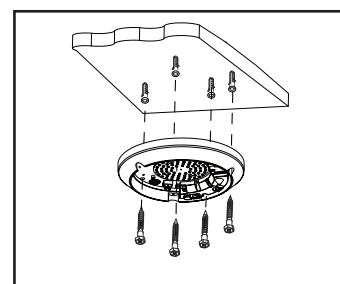

Fig.7



Concrete ceiling

- Step8 Fix the PC lampshade on the base with the screws (as Fig.8)

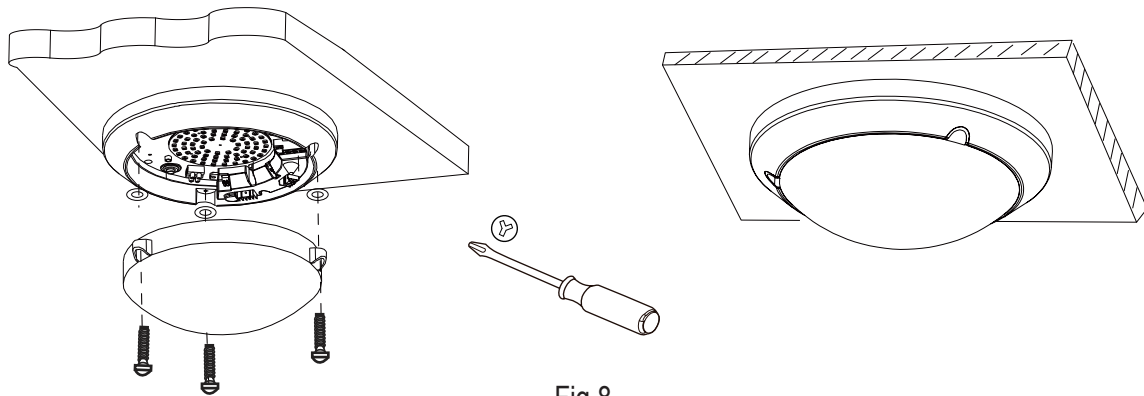
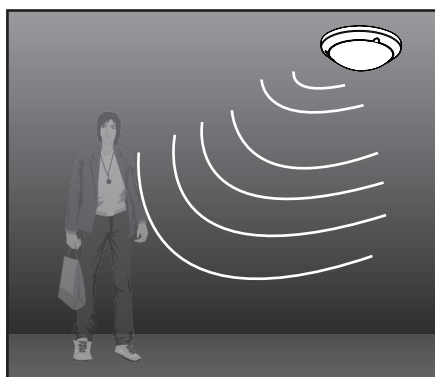
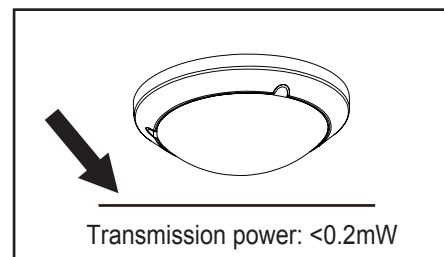

Fig.8

## Fault and the solution

Fault	Failure cause	Solution
Does not work with the load	Light-illumination set incorrectly, the load is broken	Adjust the setting of the load
	The power is off	Change the load
	There is a continuous signal in the region of the detection	Turn the power on
Work all the time with the load	The sensor have not been installed correctly	Check the settings of the detection area
When there is no a moving signal work with the load	Sensors failed to pack good cause its cannot reliably detect signal	Re-install the outer covering
	Moving signal is detected by the sensor (movement behind the wall, the movement of small objects, etc.)	Check the settings of the detection area
When there is a moving signal work with the load	The moving body is too fast or the detection area is too small	Check the settings of the detection area

**Note:** the high-frequency output of this sensor is  $<0.2\text{mW}$ -that is just one 5000<sup>th</sup> of the transmission power of a mobile phone or the output of a microwave oven.



Induction of human movement



Since entering lighting condition



## **Warning!**

- 1.The LEDS in serial can function when all the seals installed in place.
- 2.Please don't remove or connect with other lamp when powered on.
- 3.When the LEDS in serial are damaged ,you need experienced technician to repair using the same rating LEDS

Please confirm with profession installation.

Please cut off power supply before installation and removal operations.

Make sure that you have cut off the power for safety purposes.

Improper operation caused losses, the manufacturer does not undertake any responsibility.

The screws used on the light case are common ones when sent out from the factory.The specific Y type stainless screws in the plastic bag for screws are used for fixing the lampshade after the technician has finished the installation.It is for protecting against the electric shock.